

规格承认书

Product acknowledgment

产品名称：无胶双面挠性覆铜板

Products name: 2-layer FCCL

产品规格：SF202 1018DRN250A KGN

Product Code: _____

供应商名称：广东生益科技股份有限公司

地址：广东省东莞市松山湖高新技术产业开发区工业西路5号，邮编523808。

Supplier Name and Address: NO.5, Western Industry Road, North Industry District, Dongguan SSL
SCI.&Tech.Industry Park, Dongguan City, Guangdong, P.R.China 523808

修改记录(Corrective or Changing History)

序号 No.	日期 Date	修改前 Before	修改后 After	原因 Reason

目 录

一、产品说明 Product description

二、产品介绍 Product introduction

1、产品结构 Product structure

2、编码说明 Code description

三、产品品质 Product quality

1、外观品质 Appearance quality

2、物料性能 Physical property

3、电气性能 Electrical property

四、保存条件 Storage condition

五、使用说明 Using instructions

六、测试方法 Test method

1、厚度 Thickness

2、剥离强度 Peel strength

3、尺寸稳定性 Dimensional stability

4、浸锡耐热性 Solder resistance

七、产品包装 Package

八、技术反馈 Technical Feedback

一、产品说明 Product description

本产品主要以 IPC-4202 标准进行品质管控，系用作挠性印制电路的基材。产品所有之检测方法主要参照 IPC-TM-650 标准相应章节。本产品承认书没有纳入的性能规范和测试方法等项目，以行业公认的 IPC 标准为依据。

Quality controlled of this product is mainly according to IPC-4202 standards, which used for flexible printed circuit Base material . All the test methods of product are reference to IPC-TM-650 corresponding chapter. The projects such as property specifications and test methods which not included in this specification, based on the industry recognized IPC standards.

二、产品介绍 Product introduce

1、产品结构 Product structure

18 μ m 日矿压延铜箔 Rolled copper foil
25 μ m 聚酰亚胺 PI
18 μ m 日矿压延铜箔 Rolled copper foil

2、编码说明 Code description

例如：SF202 10 18 D R N 250 A K G N

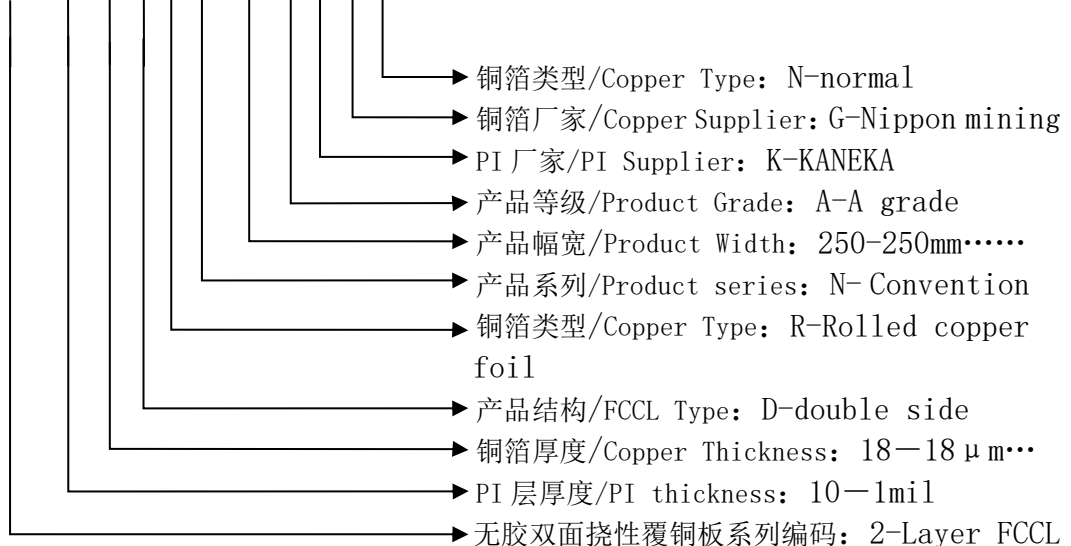

三、产品品质 Product quality

1、表观品质 Appearance quality

无胶双面覆铜板外观平整，不应有孔洞、撕裂和缺胶；PI膜内不允许有金属性夹杂物，非金属性夹杂物在任何方向的尺寸应不大于0.50mm。PI层应没有影响使用的条纹、胶粒、色斑和脏污。

2-layer FCCL should be smooth, no holes, tears and lack of adhesive; PI film does not allow metallic inclusions, the size of non-metallic inclusions in any direction shall less than 0.50mm. PI layer should be no stripes, particles, stains and dirt which affecting use.

2、物理性能 Physical Property

Test Items 检测项目	Treatment Condition 实验条件	Units 单位	Index of quality 品质标准	Test method 测试方法
Thickness 厚度	A	μm	61±10%	生益企标 Shengyi method
Length 长度	A	%	+2/-0%	生益企标 Shengyi method
Width 宽度	A	mm	+1/-0	生益企标 Shengyi method
Peel strength 剥离强度	A	N/mm	≥0.7	IPC-TM-650 2.4.9
Solder resistance 耐热性	288℃, >10s	-	无分层起泡 No delaminate	IPC-TM-650 2.4.13
Dimensional stability 尺寸稳定性	A	%	±0.1	生益企标 Shengyi method
Chemical resistance 耐化学性	After chemical exposure 暴露在化学品中后	%	≥80	IPC-TM-650 2.3.2

3、电气性能 Electrical Property

Test Items 检测项目	Treatment Condition 实验处理条件	Units 单位	Index of quality 品质标准	Test method 测试方法
Dielectric constant(1MHz) 介电常数	RH50%, 23℃, 24h	-	≤3.7	IPC-TM-650 2.5.5.3
Dissipation factor(1MHz) 介质损耗角正切	RH50%, 23℃, 24h	-	≤0.01	IPC-TM-650 2.5.5.3
Volume resistivity 体积电阻率	RH90%, 35℃, 96h	MΩ·cm	>10 ⁶	IPC-TM-650 2.5.17
Surface resistance 表面电阻	RH90%, 35℃, 96h	MΩ	>10 ⁵	IPC-TM-650 2.5.17

四、保存条件 Storage condition

无胶双面覆铜板应密封包装在干燥、无紫外光照射的环境下，在此条件下自生产日期开始可存放 12 个月；

2-layer FCCL should be stored in sealed packaging at dry environment without UV irradiation, in this condition it can be stored for twelve months since the date of manufacture.

五、使用说明 Using instructions

1、请以原包装形式放在平台上或适宜的架上，防止存放方式不当而引起的无胶双面覆铜板形变。

Please put the FCCL of original packaging on the platform or a suitable frame, to prevent deformation caused by improper storage

2、请勿采用将箱子正面向下倒出产品的做法，以免造成材料的受损；请保持箱子的正面向上，采用从箱子里面小心拿出材料的做法。

Do not pour out product from the face down box, so as to avoid damage to the material; Please keep the box face up, take the product out from the box carefully.

3、请戴无尘手套小心地操作 FCCL。碰撞、滑动等会损伤材料；裸手操作会污染 FCCL，这些缺陷都可能会对 FCCL 的使用造成不良的影响。

Please wear clean gloves and be carefully while operate the FCCL. Collision, sliding and so on will damage the material; bare-handed operation will pollute the FCCL, these defects may be adverse effects on the use of FCCL.

4、PI 遇碱性药水容易出现咬噬，因此请尽可能避免或减少 PI 接触碱性药水的时间。PI 膜较容易吸潮，请谨防吸潮。

Because of PI is easy etched by the alkaline potion , so please avoid or reduce the time contact with alkaline potion as possible. PI film is easy to absorb moisture, please prevent of moisture absorption.

5、由于挠性材料在生产加工过程中会产生一定的涨缩，因此在批量生产之前需结合板子结构及实际情况整理出 FCCL 合适的补偿参数，以免造成后续对位不良现象。

Because the FPCB process will bring some expansion and contraction, so need to make a suitable compensation parameters of FCCL before mass production according to FPCB structure and the actual process situation, in order to avoid misalignments.

6、FCCL 在常温或者空调环境下打开包装后请尽快使用，以免由于储存条件不当造成吸潮等带来的不良缺陷。投料剩余的尾数，若暂时不用，请及时密封包装送回冷库存放。

Please use the FCCL as soon as possible after opening the package at room temperature or

air-conditioned environment, in order to avoid defects such as absorb moisture, which caused by wrong storage conditions. If no need for the remaining mantissa, please return to cold storage with sealed package.

六、测试方法 Test method

此承认书所列测试项目仅为行业内 IQC 对 FCCL 进行测试之常规项目，如剥离强度、耐热性、尺寸稳定性等。对 FCCL 的其它测试项目，如电气特性测试方法、阻燃性测试方法等不再单独列出。

The test items of this specification are normal IQC test items for FCCL, such as the peel strength, heat resistance, dimensional stability. Other tests items such as the electrical property, flame-resistant test methods are no longer listed separately.

1、厚度 Thickness

用千分尺测量 FCCL 宽度方向左、中、右 3 个位置的厚度值（如下图所示），取 3 个值的平均值为产品的厚度值。

Use a micrometer to measure the thickness of three positions (width direction of the left, middle and right), which is the FCCL, as shown below. Take the average of three data for the thickness of product.

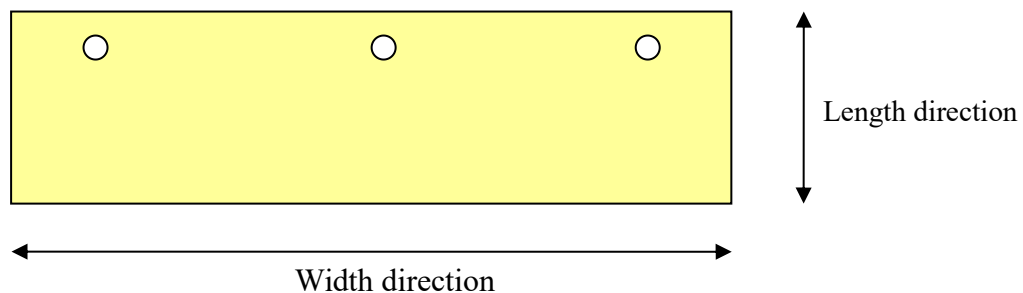

2、剥离强度 Peel strength

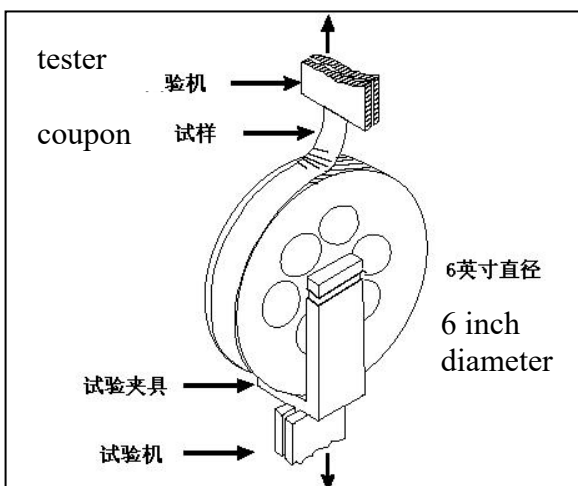

fixture

tester

2.1 样品制作 coupon prepare:

①、采用蚀刻方法制作尺寸为 $3.0 \pm 1\text{mm} \times 100\text{mm}$ 的试样。

etching a sample with size of $3.0 \pm 1\text{mm} \times 100\text{mm}$.

2.2 测试方法 Test method:

①、将试样用双面胶带、胶粘剂和/或机械夹具固定在试验夹具上。

Take the sample stickup to the test fixture with double sided adhesive tape and / or with mechanical clamps

②、剥离长度为 50mm 范围内，最初剥起固定入夹具的 10mm 不计入。以 50mm/min 的速度（滑块速度）剥离试样。剥离负载应在试验机量程的 15-85% 范围内。至少剥离 50mm，最初的 6mm 可忽略。

In the peel length of 50mm range, the first 10mm begin to peel which fix in the fixture is not included. Peel the sample with speed of 50 mm/min (crosshead speed). Peel load should be in 15-85% of test machine range. Peel length should at least 50mm, the initially 6mm can be ignored.

③、观察并记录剥离过程中的最小拉力。测量试样条的实际宽度，准确至 0.02mm。

Observe and record the minimum tensile strength of the stripping process. Measure the actual wire width of sample, accurate to 0.02mm.

2.3 计算方法 calculating method : 剥离强度 (N/mm) = 最小拉力 (N) / 试样导线宽度 (mm)。

Peel strength (N / mm) = minimum tensile strength (N) / sample wire width (mm).

3、尺寸稳定性 Dimensional stability

3.1 样品图形 coupon pattern

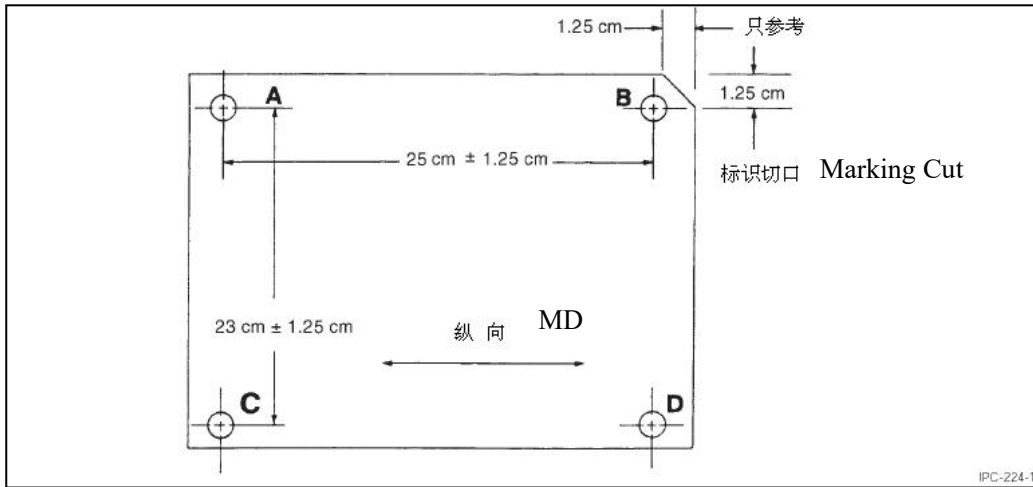

3.2 测试方法 Test method

①、按以上样品图形制备样品，测量各孔间或各线间的中心距，记作初始测量值 (I)

Samples were prepared according to the above sample graph, measure the center distance between the lines or the wells, referred as the initial data (I).

②、将样品平铺放入烘箱中，经过 150°C/30min 的烘烤，然后将样品自然平整的放置在测试台上。

Put the sample into the oven at 150 °C , after thirty minutes. Then put the sample on the test platform natural and steady .

④、重新测量各孔间或各线间的中心距，记作最终测量值 (F) 。

Measure the center distance of each hole or each line again, referred as the final measured data (F).

3.3 计算方法 Calculating method

$$M.D.(%) = \frac{\frac{(A-B)_F - (A-B)_I}{(A-B)_I} + \frac{(C-D)_F - (C-D)_I}{(C-D)_I}}{2} \times 100$$

$$T.D.(%) = \frac{\frac{(A-C)_F - (A-C)_I}{(A-C)_I} + \frac{(B-D)_F - (B-D)_I}{(B-D)_I}}{2} \times 100$$

4、浸锡耐热性 Solder resistance

4.1 样品制作 Coupon prepare:

将测试材料裁切成 5cm 大小的正方形，每个测试材料制备 3 个样品；

Cut the sample into the size of 5cm square, 3 coupons were prepared.

4.2 测试方法 Test method:

样品进行 135℃ 烘烤 1h 除湿处理后浸入温度为 288℃ 的高温锡炉，浸入 10s 后取出观察；

The coupon were baked at 135 °C for 1h to dehumidify, then dipped into the solder of 288 °C for 10s, removed and observation;







4.3 测试评判 Pass judgment:

样品无分层起泡等不良。

No delaminate and blister

七、产品包装 Package

覆盖膜包装方法如下 The package of coverlay as follow:

步骤 step	1. 包隔离纸 Packed with paper	2. 包缓冲膜 Packed with cushion film	3. 贴小标签 Stick the small label
图表 picture			
步骤 step	4. 套塑料袋后扎带封口 Pack the plastic bag and seal.	5. 套包装方环 pack the square ring	6. 装包装箱 put in the box
图表 picture			
步骤 step	7. 贴检验单 Stick inspection label	8. 包装纸箱封口 seal the carton	



图表
picture

产品内外标签单如下图（左图绿色标签单贴在包装箱外，右图白色标签单在产品塑料管内）：

The label inside and outside of product as shown below (left green label stick outside the box, right white label stick inside the plastic tube of product).

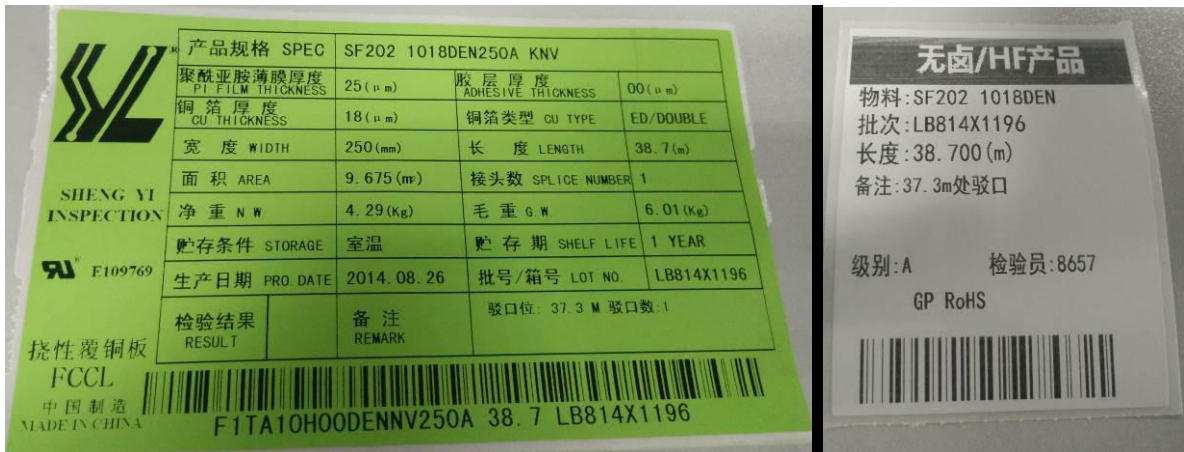

产品的接头数和接头间的最短距离如下表

The splices and splice-free length of product in the follow table:

卷长（米） Length of roll	接头数（个） splices	接头间最短距离（米） Minimum length between splices (m)
卷长 Length ≤ 50	≤ 2	5
50 < 卷长 length ≤ 100	≤ 3	10
100 < 卷长 length ≤ 200	≤ 5	10

每批产品的出货检测报告随货送达。

*Test report of each batch product is provide with the goods delivered.

八、技术反馈 Technical feedback

贵司在使用我司产品过程中，若有任何疑问和建议，请随时直接或通过贵司采购联系我们的技术或业务人员，我们将在第一时间给贵司提供技术服务。

If you have any doubts and suggestions while using our products, please contact our technical engineer and seller directly or through the purchaser at any time. We will provide technical services to your company in the first time.

对产品特殊案例中无法满足使用要求或有疑问的情况，双方依据行业相关标准和具体情况秉持真诚合作的原则进行协商处理。

If the products could not meet the requirements or have any questions in special cases, we will deal the problem with principle of sincere cooperation, and base on the correlative industry standards and actual situation.